

LiFe Premium Series

---

# Installation and Operation Manual

---

Your complete installation guide for LiFe2433P,  
LiFe4822P, LiFe4833P and LiFe12033P batteries

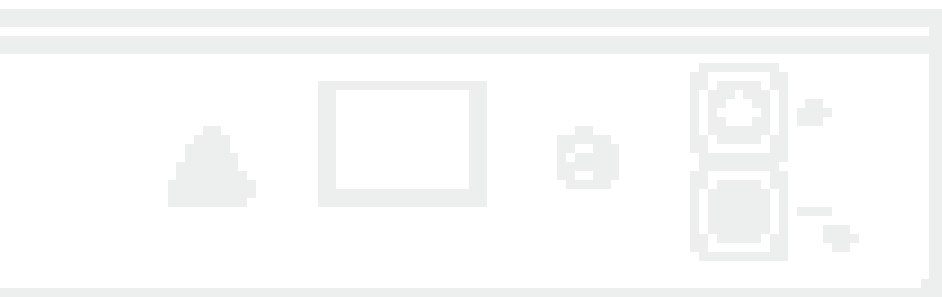

# CONTENTS

<b>1. INTRODUCTION</b>	<b>3</b>	4.6. Battery Alarm and Communication Installation	14
<b>2. SAFETY</b>	<b>3</b>	4.6.1. Data Logging	15
2.1 Transportation	3	4.6.2. PowerLink	16
2.2 Basic Safety	3	4.6.3. PowerLink Installation	16
2.3 Handling	3	<b>5. BATTERY OPERATION</b>	<b>17</b>
2.4 Storage Of Battery	4	5.1 Main Status Led	17
2.5 Life Support	4	5.2 Bms Status Led (Life12033p Only)	17
2.6 Damaged Battery*	4	5.3 Battery Power Up / Shut Down Procedure	18
2.7 Fire*	4	5.3.1 Battery System Startup	18
2.8 Qualified Person (Installer)	4	5.3.2 Battery Shut Down	18
<b>3. PRODUCT INFORMATION</b>	<b>5</b>	5.4. Full Recharge Upon First Installation	19
3.1 Weight and dimensions	5	5.5. Calibration to 100% (Weekly recharge to 100%)	19
3.2. Inclusions	5	5.6. SoC (State of Charge) Drift	19
3.3 specifications	6	<b>6. TROUBLESHOOTING</b>	<b>20</b>
3.4 Charging and Discharging	7	7.1. Over Discharged Battery Recovery	20
3.4.1. Primary Charging Source	7	7.1.2. BMS Threshold Soft Shutdown	20
3.4.2. Secondary Charging Source	7	7.1.3. Soft Shutdown Recovery	20
3.4.3. Calibration to 100%	7	7.1.3. BMS Threshold Hard Shutdown	20
3.4.4. Battery Charging Requirements PCE for P Series	7	7.1.4. Hard Shutdown Recovery	20
3.4.5. Charging Curves P Series	8	<b>7. MAINTENANCE</b>	<b>21</b>
3.4.6. Discharging Curves P Series	9	<b>8. UPGRADING BATTERY CAPACITY</b>	<b>22</b>
3.4.7. State of Charge Vs Discharge Voltage P Series	10	<b>9. CAPACITY TESTING BATTERY</b>	<b>22</b>
3.4.8. Over Discharged battery	10	<b>10. END OF LIFE</b>	<b>23</b>
3.4.9. Circuit Breaker Characteristic	11	<b>11. WARRANTY</b>	<b>23</b>
<b>4. INSTALLATION</b>	<b>12</b>		
4.1 Location and Environment	12		
4.1.1. Extreme Humidity Climates	12		
4.2. Battery Installation	13		
4.2.1. Custom Cabinets	13		
4.2.2. Battery Orientation Stationary Application	13		
4.2.3. Battery Orientation Pre-Assembled BESS or BS Systems	13		
4.2.4. Battery Orientation Motorhomes, RV's, Trailers, Vehicles, Trucks, Buses or Similar	13		
4.3 Battery Connections	14		
4.4. Main DC Connections	14		
4.5. Case Earthing	14		

# 1. INTRODUCTION

The LiFe Premium P Series Lithium Ferro Phosphate (LFP) batteries by PowerPlus Energy are designed and manufactured in Australia for the world's harshest conditions to be a simple, flexible and reliable energy storage solution.

# 2. SAFETY



<p>As a result, the LiFe Premium P Series batteries can be easily installed with most inverter and charger combinations, UPS, rectifiers, DC or AC coupled charging devices, on-grid and off-grid in single, dual or three phase applications.</p>	<p>There are almost no limitations in applications and suitable devices that can charge or discharge the LiFe Premium P Series battery.</p> <p>The LiFe Premium P Series battery is available in 24V and 48V and 120V.</p>
--	--

## 2.1 TRANSPORTATION

PowerPlus Energy's LiFe series LFP Batteries are classed as Dangerous Goods (DG) Class 9 UN3480.

The batteries are safe for road transport and are shipped in a partially discharged state with terminal protection and circuit breaker off.

Batteries where possible, should be shipped in the original manufacturer's packaging, positioned horizontally and secured to a pallet. Batteries should not be stacked more than 6 batteries tall or shipped vertically.

## 2.2 BASIC SAFETY

The following precautions should be observed.

Battery pack:

- is intended to be a 2 person lift when installing
- should not be exposed to pressure, or have objects placed on top of them

The battery module **should not** be:

- exposed to temperatures above or below the temperature ratings specified within this manual
- touched if wet
- installed in direct sunlight

- exposed to strong impacts
- crushed or punctured
- disassembled; it contains no maintainable components
- opened for repair; it is non-user serviceable

Battery connectors **should not**:

- touch conductive surfaces unless intended to do so

The battery **should be**:

- kept dry at all times
- kept away from animals and children

## 2.3 HANDLING

- use battery only as directed.
- handle battery with care when installing or transporting
- the batteries are heavy and proper lifting techniques or equipment should be applied

**Do not:**

- use the battery if it appears damaged or broken
- use chemicals to clean the battery
- touch the DC terminals
- touch the DC busbar

## 2.4 STORAGE OF BATTERY

The battery **should be**:

- stored horizontally and stacked no more than 6 batteries tall without extra support
- kept in a dry environment away from moisture
- stored away from incompatible substances
- stored between 0°C to 35°C, however close to 25°C should be considered for long term storage

**After 6 months of storage the battery may need cell balancing and should be charged.**

Issues charging after long term storage should be discussed with PowerPlus Energy.

## 2.5 LIFE SUPPORT

Our batteries **should not** be used in life support applications where failure of our LiFe batteries can reasonably be expected to cause failure of the life support equipment or effect operation of such equipment.

## 2.6 DAMAGED BATTERY\*

A damaged battery should not be used and should be returned to PowerPlus Energy or disposed of via a recycling facility. Leaking electrolyte can cause skin irritation and chemical burns, so contact should be avoided.



Eye Contact	Rinse gently with running water and seek medical attention if irritation develops
Skin Contact	Rinse gently with running water and seek medical attention if irritation develops
Ingestion	If ingested, do not induce vomiting and contact your local poisons information centre or doctor.
Inhalation	Evacuate area and seek professional medical attention immediately.

## 2.7 FIRE\*

Should the battery pack catch on fire or starts to emit smoke, (for small fire or small emissions of smoke) use ABC or dry chemical fire extinguisher.

Evacuate the area and call emergency services.

Toxic gases may be produced if the battery catches fire.

The battery needs to be rapidly cooled to prevent any heat or fire spreading.

## 2.8 QUALIFIED PERSON (INSTALLER)

This operation manual and task sets within regarding installation should be carried out by a suitable qualified and skilled person.

The installer needs to be a person with adequate skills, qualifications and experience.

They **should**:

- Have a thorough understanding of operations, design and installation principles of battery energy storage systems.
- Have a thorough understanding of all dangers and risks associated with installing and using electrical devices.
- Hold all local, state and country base qualifications to carry out such work.
- Adhere to all safety and installations requirements within this manual.

*\*Refer to product SDS document for more details available from PowerPlus Energy's web page or upon request.*

### 3. PRODUCT INFORMATION

The technical information presented here within, outlines the physical and electrical characteristics of the battery and what environment they should be installed in.

The LiFe P Series batteries are self-managed with an internal BMS within each battery to protect it from over voltage, under voltage, over temperature and over current.

The battery does not require communication with the Power Control Electronics (PCEs) to operate. The LiFe P Series can operate with PCE (Power Control Electronics) that do not require communications to operate.

If you are unsure, please consult your PowerPlus Energy expert or the PowerPlus Energy web page for advice.

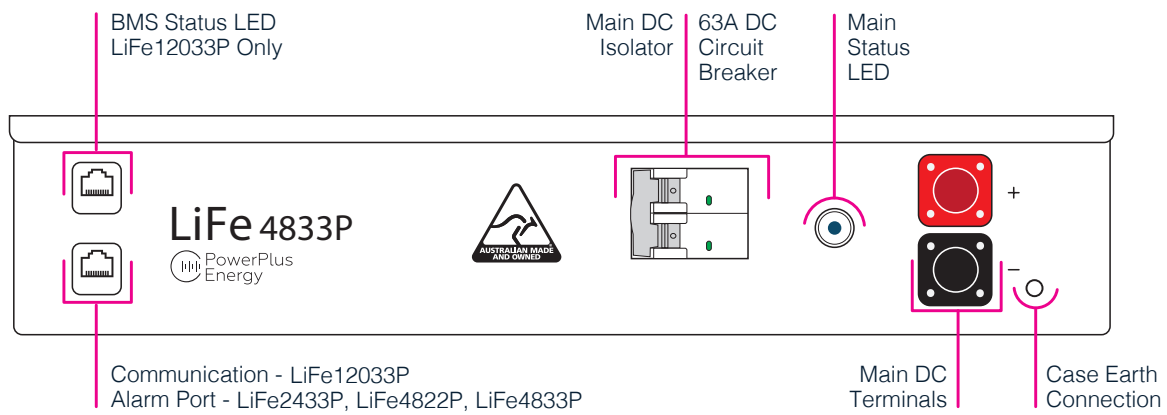

#### 3.1 WEIGHT AND DIMENSIONS

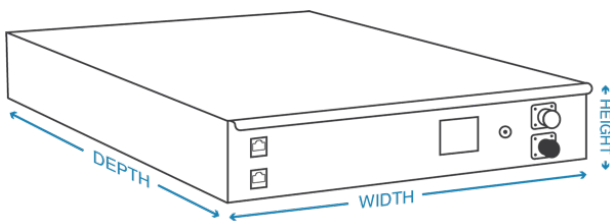

	LiFe2433P LiFe4833P LiFe12033P	LiFe4822P
Depth	635mm	420mm
Width	434mm	434mm
Height	88mm	88mm
Weight	41kg	30kg

#### 3.2. INCLUSIONS

Each battery comes supplied in a cardboard box that should be retained in case there is a need to return the battery to PowerPlus Energy. All other accessories are sold separately.

	DC Connector
Positive DC connection	1 x SLPPA16BSR
Negative DC Connection	1 x SLPPA16BSB
25mm to 16mm reducer	x2



### 3.3 SPECIFICATIONS

	LiFe2433P	LiFe4833P	LiFe4822P	LiFe12033P
Nominal DC Voltage	25.6V	51.2V		128.0V
Operational Voltage Window	20V to 28.8V	40V to 57.6V		(110V) / 123.2V to 144V
Nominal Capacity	3.3kWh (3.277) / 128Ah	3.3kWh (3.277) / 64Ah	2.2kWh (2.211) / 43Ah	3.3kWh (3.277) / 25.6Ah
Usable Capacity	3.3kWh (3.277)	3.3kWh (3.277)	2.2kWh (2.211)	2.97kWh (2.95)
Recommended Usable Capacity	2.64kWh	2.64kWh	1.76kWh	2.64kWh
Depth of Discharge	Up to 100%			Up to 90%
Recommended Depth of Discharge	80% or less			
Continuous Discharge C-Rate	0.5C (C2)	1C (C1)		
Continuous Discharge Current	63A	63A	43A	25A
Continuous Discharge Power	1.61kW	3.22kW	2.20kW	3.20kW
Maximum Discharge (Limited by K-Curve Circuit Breaker) (*Refer to Install Manual for circuit breaker characteristics)	63A* (1.61kW)	63A* (3.22kW)	63A* (3.22kW)	25A* (3.20kW)
Maximum Charge Current	63A	63A	63A	25A
Warrantable Charge Current	63A	32A	21.5A	12.8A
Warrantable Charge Power	1.61kW	1.63kW	1.10kW	1.63kW
Prospective Fault Current (1ms)	250A			110A
Circuit Breaker (K-Curve)	2-Pole 63A 360VDC			2-Pole 25A 360VDC
Lithium Composition	Lithium Ferro Phosphate (LiFeP04 or LFP)			
Operating Temperature Range	Charge: 0° to 55°C / Discharge -20° to 60°C			
Operating Temperature Range	0 to 35°C			
Operating Humidity	85% Non-condensating			
BMS Over-Volt Cell Level Protection	3.9V/Cell			3.7V/Cell Average
BMS Under-Volt Cell Level Protection	2.0V/Cell			Soft Shut down 3.08V/ Cell Hard Shut down 2.75V/ Cell
BMS Over-Temp Cut Off	65°C			55°C Charge 60°C Discharge
BMS Max Trip Current	200A			100A
Self Discharge	14% Per Annum			
Altitude	< 2000m (seek manufacturers advice above 2000m)			
Battery Mounting Options	Standard 19" Rack Mount / Horizontal / Vertical			
Terminal Connections	Amphenol Surlok 100A Non-keyed			
IP Rating	IP40			
Efficiency	>96%			
Cooling	Natural convection			
Parallel Connection	Unlimited - Refer to Manufacturer			
Series Connection	Not Permitted			
Alarm Output	Normally Closed. Volt-free, 200mA 60V Max			
Communications	Alarm Output			Battery Performance data via PowerLink Data device +Alarm output
Module Weight	41kg		30kg	41kg
Battery Dimensions	635mm D x 434mm W x 88mm H		420mm D x 434mm W x 88mm H	635mm D x 434mm W x 88mm H
Arc Flash Incident Energy IEm in Cal/cm2 (45cm)	0.25	0.36	0.36	0.54
Arc Flash Incident Energy AFB in cm	20.45	24.45	24.45	30.19
Certifications	Pending IEC: 62619:2017, UN38.3, EMC	Pending IEC: 62619:2017, UN38.3, EMC	Pending IEC: 62619:2017, UN38.3, EMC	Pending IEC: 62619:2017, UN38.3, EMC
Warranty	10 Years (conditions apply)			

### 3.4 CHARGING AND DISCHARGING

The battery should be charged and discharged within the operating temperature windows as outlined within the specifications and as indicated in the Charge Discharge table below “Connected PCE Programming Requirements”. All currents are maximum for each battery, and should be taken into consideration when multiple devices are charging the battery.

#### 3.4.1. PRIMARY CHARGING SOURCE

A Primary Charging Source should be identified in the system and programmed to charge the batteries as outlined in the table below. A primary charging source, is the charging device that will be used to charge the battery for 75% of the time (charge energy) or higher.

#### 3.4.2. SECONDARY CHARGING SOURCE

A Secondary Charging Source can also be used, the preference is to also have these devices programmed to the charging settings in the table “Connected PCE Programming Requirements”. However if this is not possible, they can be used as long as the output voltage does not exceed the upper voltage of the Operational Voltage Window of the battery, does not exceed the Max Charge Current, and does not account for more than 25% of the charging (energy) of the battery.

#### Example

Primary Charging Source = Solar PV will be used to perform 75% of charging and will be programmed as per below table.

Secondary Charging Source = Wind Turbine will be used to supply approximately 25% of the charging, however can not have the voltage adjusted as per the specific charging voltages as specified in the table “Connected PCE Programming Requirements”, and will not exceed the Operational Voltage Window or Max Charge Current/Power of the battery.

#### 3.4.3. CALIBRATION TO 100%

Calibration to 100% every 7 days (minimum) is required to perform a cell balance maintenance charge. Cell balancing allows the BMS to equalise the battery cells to limit battery capacity slip and ensures battery will accept the charge voltage correctly.

##### Calibration to 100% is achieved by:

Charge batteries at specified “Continuous Charge Voltage” and no greater than the specified Maximum Charge Current.

Battery is considered full after battery is absorbing less than 1% of maximum charge current after being held at specified charge voltage for 30minutes minimum.

If PowerPlus Energy has released Custom Charge Settings for your connected PCE, then these instructions can be followed instead.

#### 3.4.4. BATTERY CHARGING REQUIREMENTS PCE FOR P SERIES

##### Connected PCE Programming Requirements

	LiFe2433P	LiFe4833P	LiFe4822P	LiFe12033P
Shutdown DC Voltage @0.5C	24.0V	48.0V		123.75V
Shutdown Voltage Recommended	25.1V	50.2V		125.5V
Recovery / Restart Voltage	26V	52V		130V
Continuous Charge Voltage	28.8V	57.6V		142V
Continuous Charge Transition	Battery is considered full after battery is absorbing less than 1% of maximum charge current after being held at specified charge voltage for 30minutes minimum.			
Float Voltage Cyclic (Short Term Float) (Example Solar Application)	28.8V	57.6V		142V
Float Voltage Standby (Long Term Float) (Example UPS Application)	27.2V to 28V	54.4V to 56V		140V
Charge Current	63A	32A	21.5A	12.8A
Peukert Exponent	1.02			
Shutdown SoC Recommended	20%			
Calibration to 100%	Every 7 days or more frequent where possible. (Ensures cell balancing is performed and keeps external SoC counter more accurate)			

3.4.5. CHARGING CURVES P SERIES

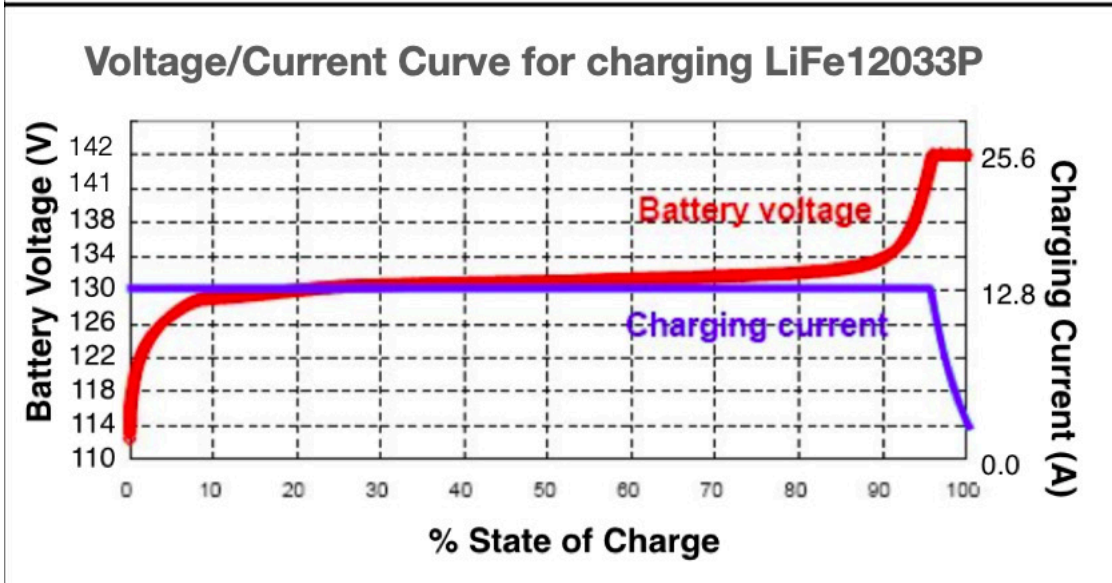
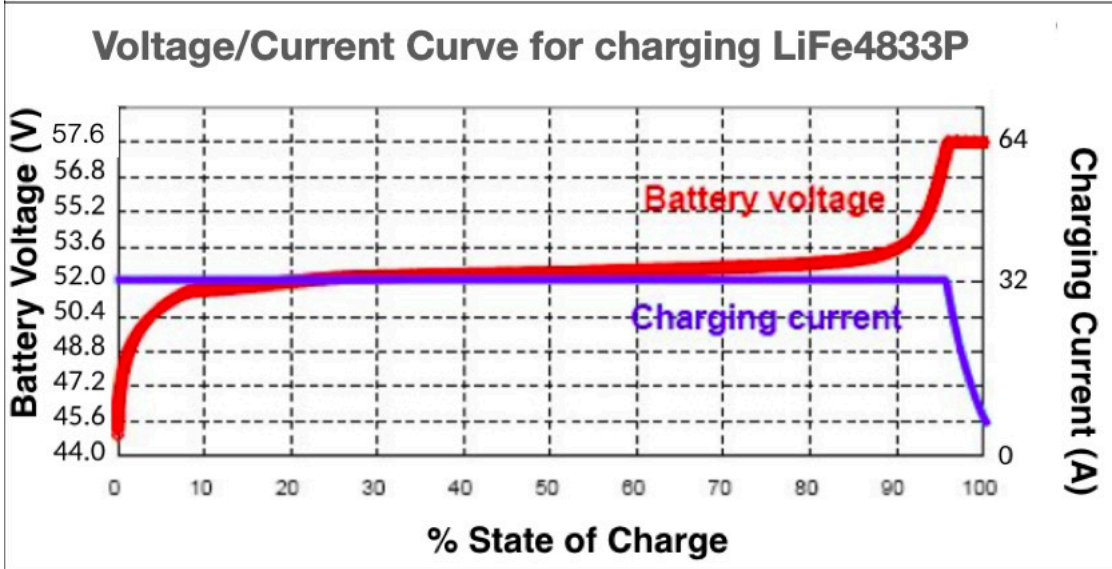
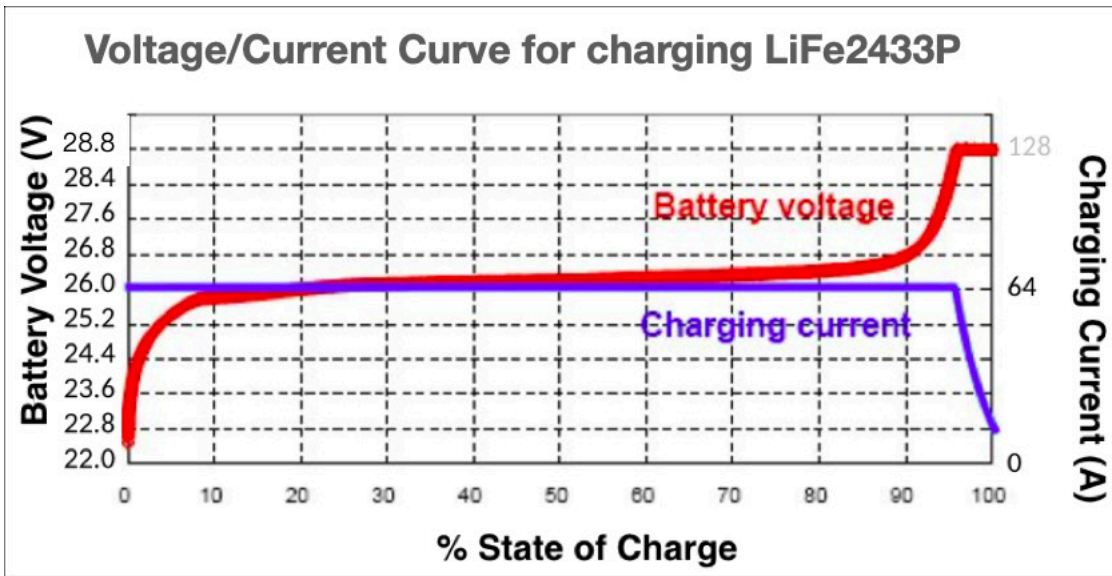



3.4.6. DISCHARGING CURVES P SERIES

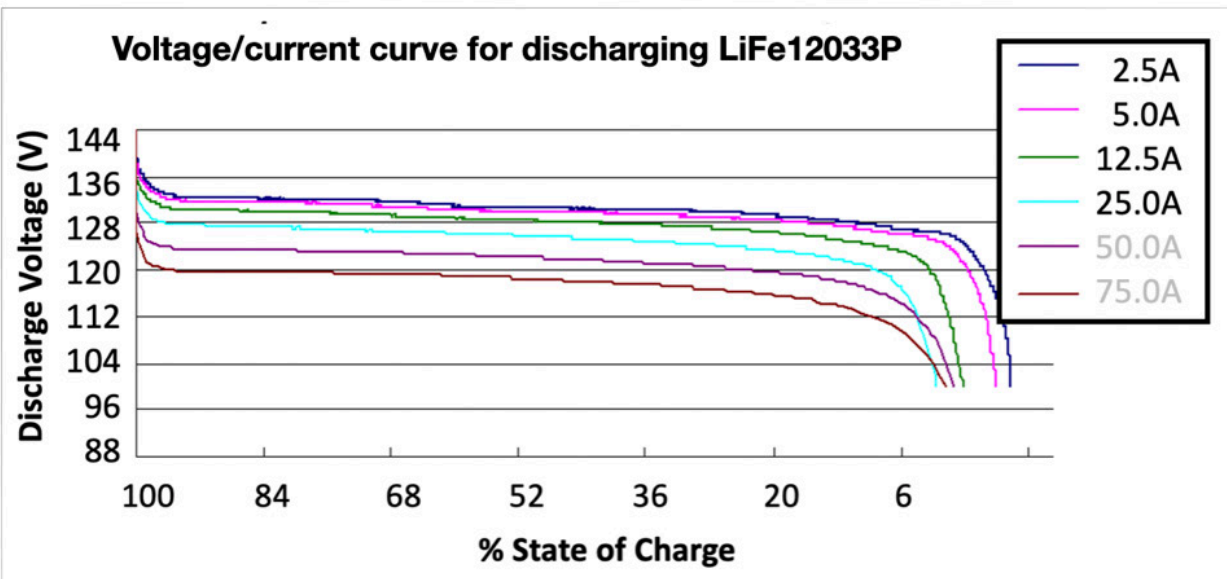
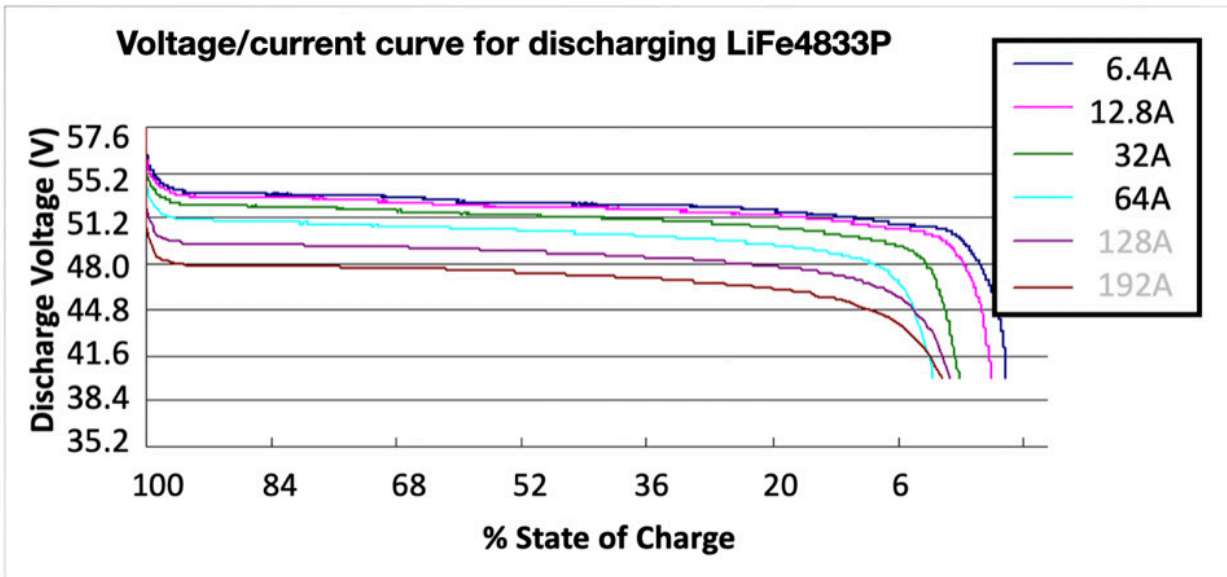
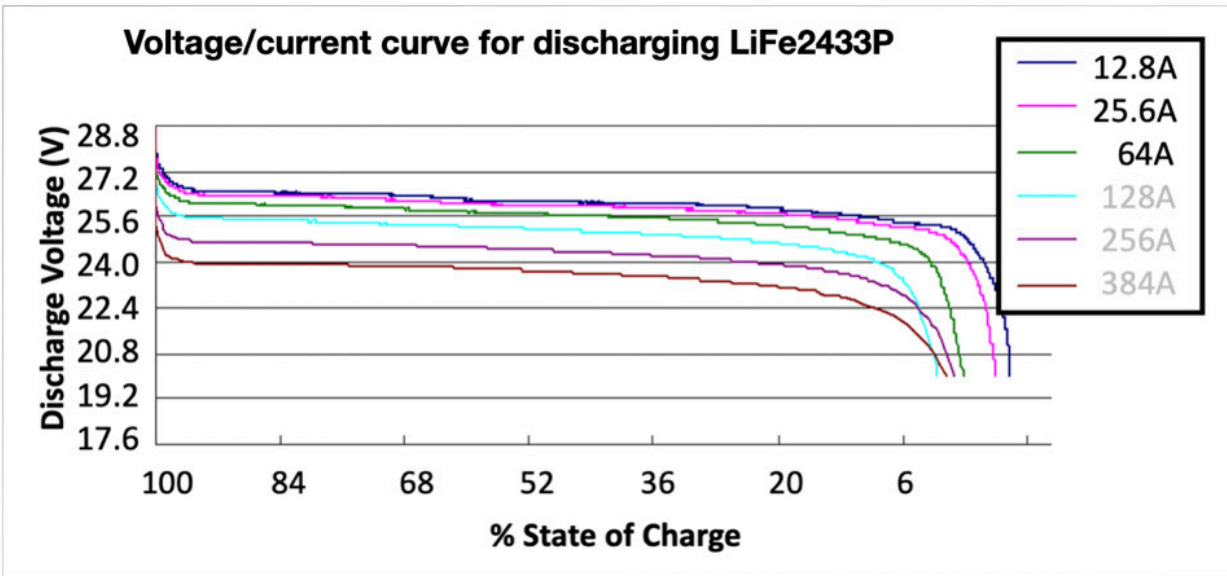

### 3.4.7. STATE OF CHARGE VS DISCHARGE VOLTAGE P SERIES

The below table can be used a guide for referencing voltage against energy in the battery.

The below figures are taken at 25°C and with a 0.5C load applied.

	LiFe2433P	LiFe4833P	LiFe12033P
100%	>26.50V	>53.00V	>132.50V
99%	26.25V	52.50V	131.25V
98%	26.00V	52.00V	130.00V
97%	25.88V	51.75V	129.38V
96%	25.86V	51.72V	129.30V
95%	25.85V	51.70V	129.5V
90%	25.83V	51.65V	129.13V
80%	25.75V	51.50V	128.75V
70%	25.66V	51.32V	128.30V
60%	25.58V	51.15V	127.88V
50%	25.50V	51.00V	127.50V
40%	25.38V	50.75V	126.88V
30%	25.25V	50.50V	126.25V
20%	25.10V	50.20V	125.50V
10%	24.75V	49.50V	123.75V
0%	24.00V	48.00V	120.00V

### 3.4.8. OVER DISCHARGED BATTERY

In the event that the batteries low voltage protection circuit has operated to protect the battery from excessive discharge, it is important that the battery is charge to 100% within 7 days. Leaving the battery in a discharged can cause irreversible damage to the battery or battery capacity.

### 3.4.9. CIRCUIT BREAKER CHARACTERISTIC

The integrated non-polarised DC circuit breaker is dual pole and a K curve type. The table below outlines the trip times based on current.

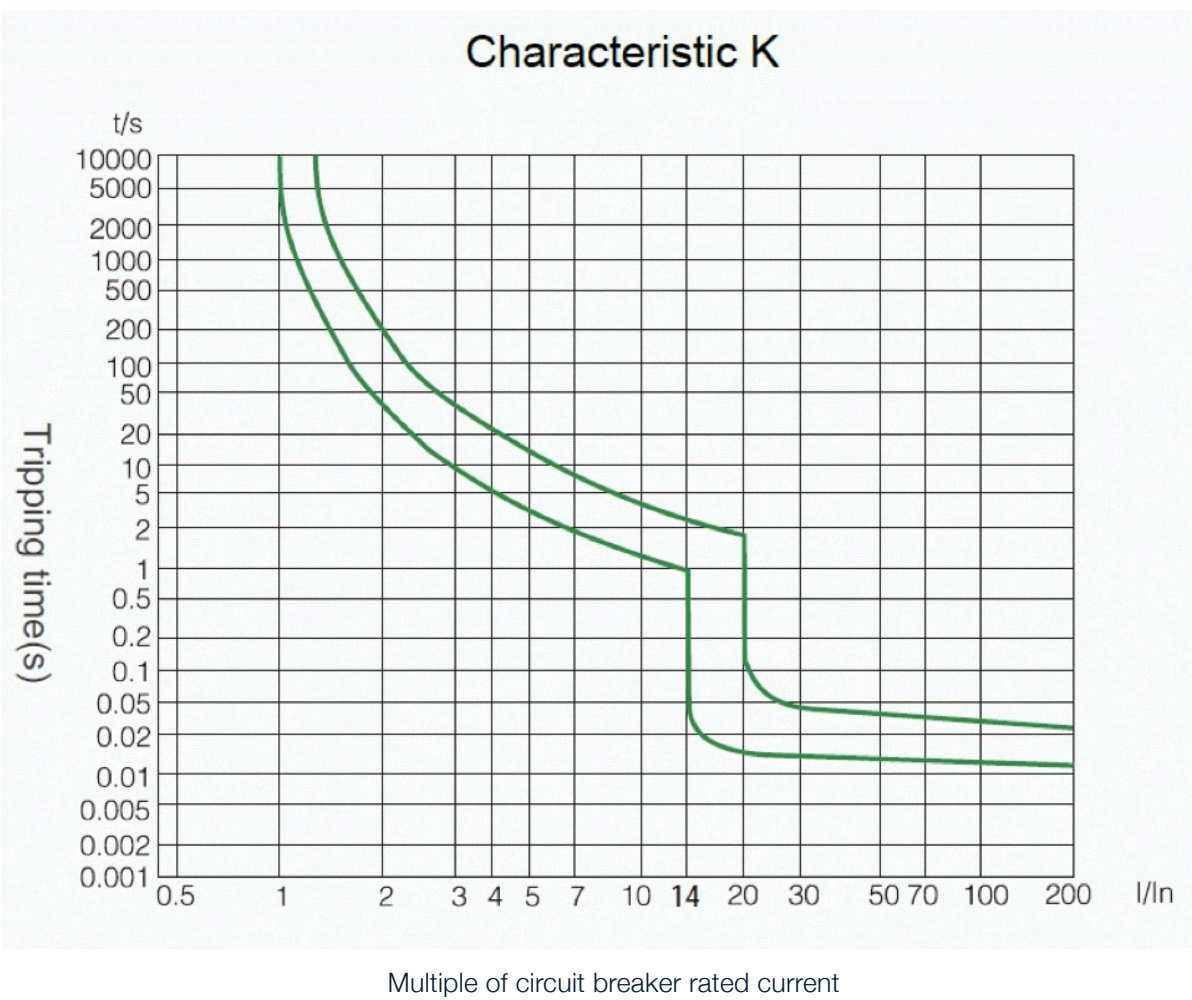

## 4. INSTALLATION

---

Installation should be carefully considered and all aspects of the specifications should be understood to determine a suitable location and way of installing the battery.

### 4.1 LOCATION AND ENVIRONMENT

The location of the battery should be in accordance with the IP rating and operating temperature range specified in the specification section of this manual.

The location of the batteries should meet the below conditions:

- The battery should not be installed where direct contact of salt air may be possible. If unavoidable, appropriate air filtration must be used to prevent salt air contacting the battery, and the battery installation should be indoors or an IP66 or greater enclosure.
- The floor is level and free from obstructions.
- There are no explosive or flammable materials nearby.
- The ideal temperature around the battery is between 15°C and 30°C.
- Operation of charge and discharge outside of the ideal temperature should be limited to 0.2°C and still remain within the operating temperature range as specified in the specification.
- The temperature and humidity should remain as constant as possible.
- The area is of a clean environment with minimal dust.
- The area or enclosure is vermin proof to suit your environmental locations.
- The batteries and battery cabinets/housings are not exposed to direct sunlight.

The LiFe Premium P Series battery is designed to be installed in a 19 inch data rack assembly or an electrical enclosure of your choice. If the battery is to be installed outdoors a suitable IP54 or greater enclosure should be used.

#### 4.1.1. EXTREME HUMIDITY CLIMATES

When batteries are being installed in climates of extreme humidity, extra precaution should be taken.

- A humidity control agent (i.e. chemical which absorbs humidity) may be required inside the enclosure, with controlled airflow to expel moist air.
- And or, the battery system to be installed in a moisture and climate controlled room (example, reverse cycle air-conditioner cooled).
- The temperature of the cabinet should be held at a temperature above dew point at all times.

## 4.2. BATTERY INSTALLATION

PowerPlus Energy highly recommends our range of Rack or Slimline Series, indoor and outdoor cabinets. Full specification details are available on the PowerPlus Energy web page.

### 4.2.1. CUSTOM CABINETS

The battery has been designed to fit into a standard 800mm deep 19inch rack enclosure.

- If you are building your own enclosure, ensure the below is considered in your design.
- If the battery is installed in to enclosures without rails, please ensure that they are securely seated to prevent accidental damage or tampering.
- If a custom enclosure or mounting method is used please ensure the batteries are not stacked more than 6 high unless battery support rails are used to distribute weight.
- Please ensure there is adequate air flow around the battery stack within the cabinet. A clearance of at least 25mm airflow around 4 sides of the stack is required as minimum.
- Please ensure the selected IP rating is correct as per your location selection.
- All interconnecting battery cables for parallel connection shall be the same length and cable size.
- A busbar is recommended for connection of all parallel battery connections.
- An appropriate way of connecting the cabinet to the PCE should be considered.
- Please follow PCE instructions for fuse, cable and connection requirements. These will vary depending on brand and product selected.

#### Maximum of 6 batteries stacked without additional support

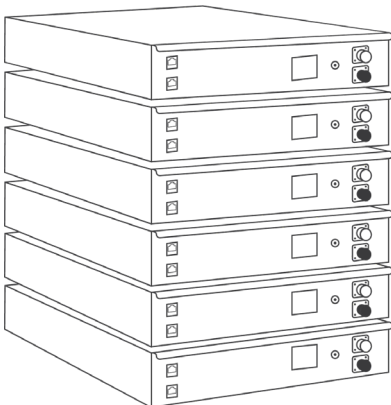

### 4.2.2. BATTERY ORIENTATION STATIONARY APPLICATION

The LiFe batteries can be mounted in 4 orientations, excluding on its face or upside down.

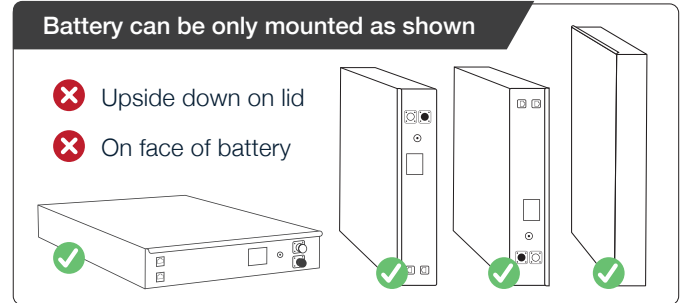

### 4.2.3. BATTERY ORIENTATION PRE-ASSEMBLED BESS OR BS SYSTEMS

Batteries should be shipped horizontally and secured in place to limit movement.

If batteries are to be subject to prolonged vibrations during transportations, they should be removed and shipped in original manufacturers packaging or a sufficient non-flammable shock mount system (like high density foam or similar) should be installed within the BESS/BS under each battery.

### 4.2.4. BATTERY ORIENTATION MOTORHOMES, RV'S, TRAILERS, VEHICLES, TRUCKS, BUSES OR SIMILAR

- Batteries should be shipped horizontally and secured in place to limit movement.
- Batteries should be positioned in a non-flammable section and be easily accessible and removable from the outside of the vehicle.
- Sufficient non-flammable shock mount system (like high density foam or similar) should be installed within the BESS/BS under each battery.

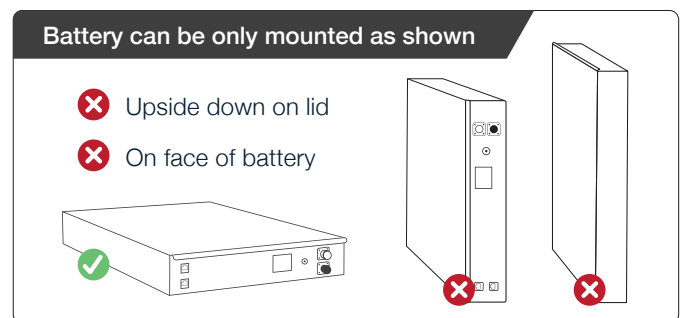

### 4.3 BATTERY CONNECTIONS

Each battery has a positive and negative Amphenol SurLok (non keyed) connector for easy snap on connection. A range of cables and mating connectors are available from any PowerPlus Energy place of purchase.

If multiple batteries are being used in parallel, the battery cables shall all be of the same length to retain equal impedance of each battery and cable set.

### 4.4. MAIN DC CONNECTIONS

The battery comes fitted with Amphenol Surlok connectors (non keyed) connectors. The table below outlines the battery connections and the mating cable connectors required. Each battery when ordered separately (without a cabinet) will come supplied with mating connectors.

Each Amphenol SurLok connector supplied by PowerPlus Energy can adequately seat 25mm single insulated or 16mm double insulated cable. A 16mm reducing sleeve is provided. Crimping of SurLok to the stripped end of the cable is performed using a standard 25mm hex crimp tool.

Before connecting the DC cable to the battery you will need to remove the safety insulating cap on the battery DC connectors and dispose of appropriately.

	Battery	Cable
Positive connection	SLPRATPSR	SLPPA16BSR
Negative Connection	SLPRATPSB	SLPPA16BSB



### 4.5. CASE EARTHING

The LiFe battery case is designed to be electrically floating and isolated from all internal battery connections and in most installations will not require earthing. However should your application require the case to be grounded a 5mm M6 bolt should be used.

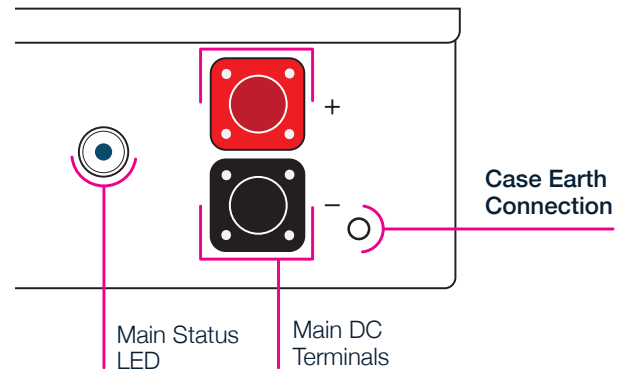

### 4.6. BATTERY ALARM AND COMMUNICATION INSTALLATION

The battery provides the ability to alarm the system manager that the battery's BMS or circuit breaker has tripped. The BMS trip will self reset once fault has been resolved or removed, however if the battery circuit breaker has tripped, it will need manual intervention.

The connectors are an RJ45 style connector. The alarm output uses pins 5 and 6 and provide a volt free contact. This volt free contact can be used to signal an external PLC or alarm circuit.

The alarm output is normally closed when energised by the battery (battery is ON and LED illuminated). When the BMS or circuit breaker trips the battery turns OFF (circuit breaker or BMS trip and LED off) and the contact will open.

The alarm outputs are designed to be daisy chained (using P/N COM003A comms cable), connecting the bottom RJ45 from one battery to the top RJ45 of the next and so on. The battery at the end of the chain (generally the bottom battery) will need to have pins 1 and 2 bridged on the bottom RJ45 terminals using bridging connector P/N COMLBA. The top connector on the last battery in the chain can be connected to an appropriate alarming circuit using one of our battery comms cables.

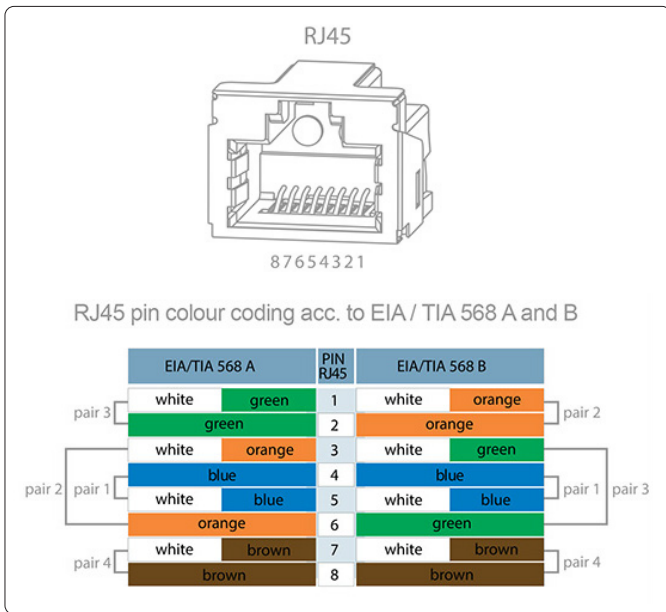

Communication Accessories	
Description	Part Number
Battery Bridge connector	COMLBA
Battery daisy chain connector lead (30cm)	COM003A
Battery Comms Cable (2 Metre)	COM020A
Battery Comms Cable (5 Metre)	COM050A
Battery Comms Cable (10 Metre)	COM100A
Battery Comms Cable (15 Metre)	COM150A
Description	Part Number
PowerLink data logger	PL001

#### 4.6.1. DATA LOGGING

The LiFe2433P, LiFe4822P and LiFe4833P batteries do not come equipped with a data output. Battery performance is monitored by the connected PCE and data presented will vary based on each product’s capabilities or monitoring options.

Diagrams below: Specific examples on how to use alarm contacts

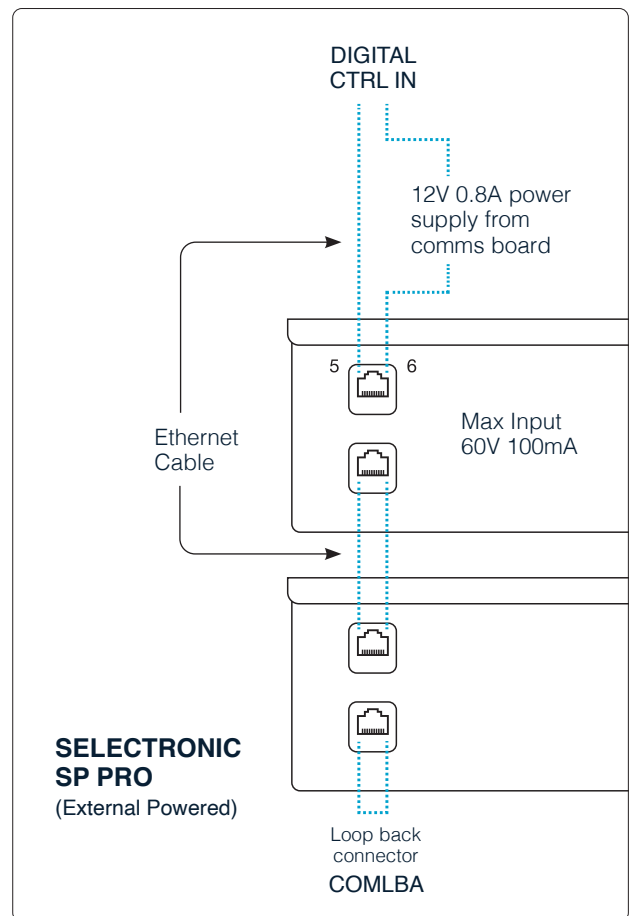
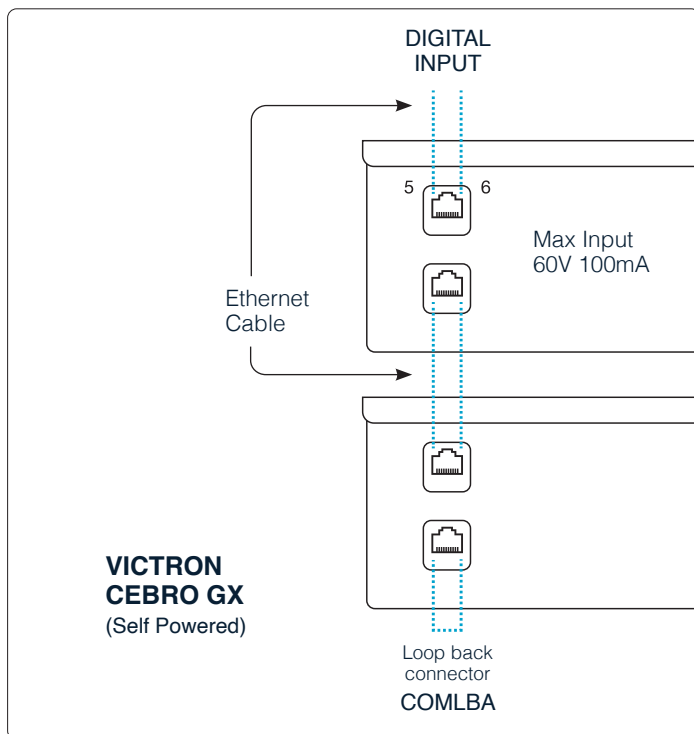

The LiFe12033P comes equipped with digital data output. The data can be accessed when connected to and configured with the PowerPlus Energy PowerLink device and via the PowerPlus Energy portal (<https://performance.powerplus-energy.com.au:3000/login>).

Refer to the PowerLink specification for full monitoring details found on our website: [powerplus-energy.com.au](https://performance.powerplus-energy.com.au)

#### 4.6.2. POWERLINK

Each PowerLink can monitor up to 20 batteries and multiple Powerlink's can be connected to the one system within PowerPlus Energy's monitoring portal (<https://performance.powerplus-energy.com.au:3000/login>).

Battery Measurements	Pack Measurements
Battery Current	Pack Current
Battery Voltage	Pack Voltage
Battery Temperature	
Coming Soon (implementation pending) State of Charge, State of Health, Throughput Energy, SNMP, CANBus,	

#### 4.6.3. POWERLINK INSTALLATION

Refer PowerLink installation guide on our web page.



# 5. BATTERY OPERATION

Now you have installed the batteries you are almost ready to energise the system. First you need to inspect your installation checking:

- polarity of all battery connections is correct
- there is no damage to cables
- all system breakers are in the OFF position
- for adequate air flow as per installation requirements
- for local installation compliance if applicable

Starting up the battery system should be done in conjunction with the PCE manufacturer's recommendations as well as this manual and any local or government safety requirements.

Each battery in the system is powered up separately by turning the double pole circuit breaker to the ON position. Once powered up, voltage will be present at the DC terminals and the Main Status LED light will glow blue.

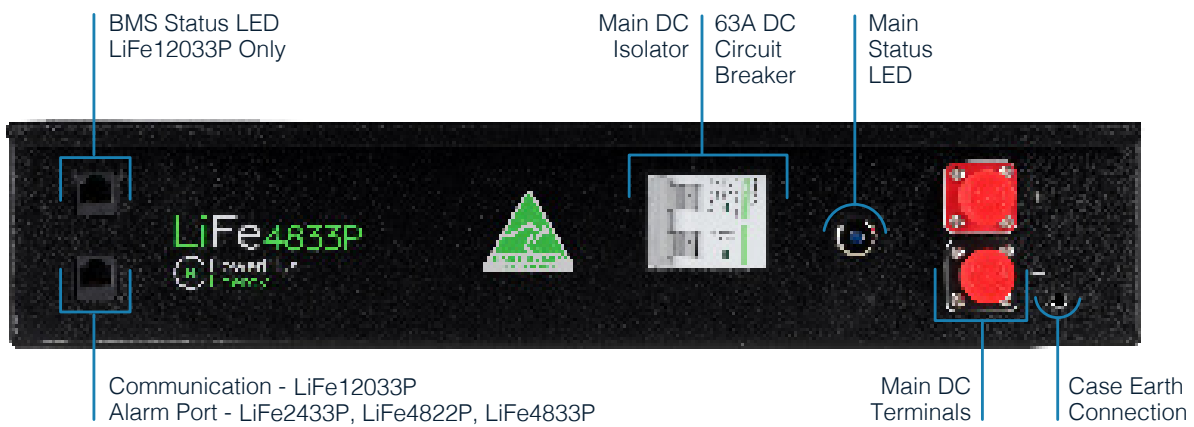

## 5.1 MAIN STATUS LED

The Main LED Status indicator is used to understand the operation of the battery and the state of the BMS.

Status	Operational State
ON	Battery is ON and allowing charge and discharge.
OFF	Battery circuit breaker is in the OFF position.
OFF	<b>Low Voltage Protection Mode</b> [Battery BMS]: Charge will still be accepted, however discharge will not be permitted until battery cell voltage is sufficient.
OFF	<b>High Voltage Protection Mode</b> [Battery BMS]: Charge will not be accepted, however discharge will continue.
OFF	<b>Temperature Protection Mode</b> [Battery BMS]: BMS has detected cell temperature outside of our operation window of MAX 55°C. Charge or discharge will be disabled until cell temperature reduces.

## 5.2 BMS STATUS LED (LIFE12033P ONLY)

This LED is complimentary to our Main Status LED and is available on the LiFe12033P.

Please refer to the colour chart (below) for details on warnings and operation signals for the LED.

NORMAL		<b>White</b> System booting / self-checks
		<b>Blue</b> Normal Operation
		<b>Cyan</b> Cell balancing in progress
		<b>Green</b> Period blink when communicating / flashes green when firmware updating
WARNINGS		<b>Magenta</b> Internal fault
		<b>Red</b> Over-temperature / over-current
		<b>Yellow</b> Over-voltage / under-voltage

### 5.3 BATTERY POWER UP / SHUT DOWN PROCEDURE

Each battery has an integrated DC circuit breaker to protect the battery in the event of a system fault and is also used to power the battery ON and OFF.

The below procedures should be used in conjunction with the system start up/shut down procedure.

**Important:** If the power system has been shutdown or charging source removed, the battery must have its circuit breaker cycled to the OFF position within 48hrs to alleviate battery discharge from self discharge or system standby discharge.

#### 5.3.1 BATTERY SYSTEM STARTUP

The battery system should be started following the startup procedure supplied with the system.

The LiFe batteries do not provide an output voltage until they are turned on. In most cases powering on the battery will be one of the first steps of starting your power system.

1. Locate and ensure your main system Isolation point is OFF.
2. Check all battery connections are correctly installed.
3. Individually (working in a systematical approach), turn each battery circuit breaker to the ON position (cycle to the right when looking at the front face of the battery face on).
4. Main Status LED will illuminate indicating voltage is present at the battery terminals.

#### 5.3.2 BATTERY SHUT DOWN

The battery system should be shutdown following the shutdown procedure supplied with the system.

The LiFe batteries will provide an isolated output when they are turned off. In most cases powering off the battery will be one of the last steps of shutting down your power system.

**Important:** The LiFe batteries should be shutdown as soon as possible or within 6 hours of a system shutdown, system fault or charging source being removed.

1. Turn off PCE.
2. Locate and ensure your main system Isolation point is OFF.
3. Individually (working in a systematical approach), turn battery circuit breakers to the OFF position (cycle to the left when looking at the front face of the battery face on).
4. Main Status LED will turn off indicating voltage is no longer present at the battery terminals.

#### CIRCUIT BREAKER ON

Flip the switch on circuit breaker to the right

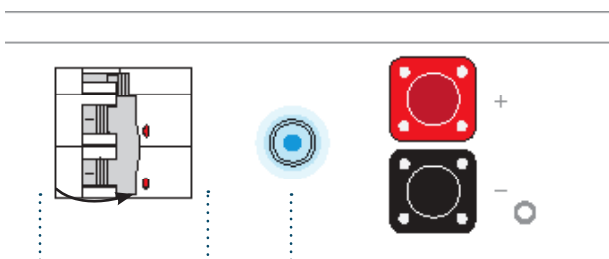

**63A DC Circuit Breaker**

**LED Indicator Light**  
Will illuminate when circuit breaker is on

#### CIRCUIT BREAKER OFF

Flip the switch on circuit breaker to the left

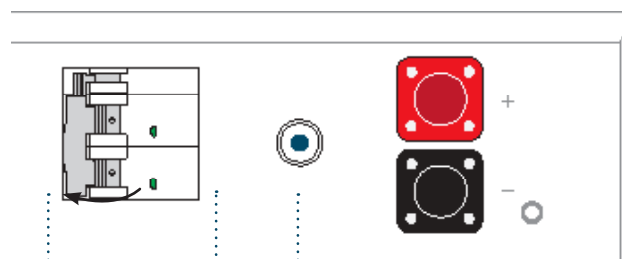

**63A DC Circuit Breaker**

**LED Indicator Light**  
Will turn off

#### 5.4. FULL RECHARGE UPON FIRST INSTALLATION

Batteries are delivered and shipped in a partial state of charge. Prior to discharging the battery it should be fully charged to the float stage.

**Important:** This first initial charge will allow the battery BMS to perform a cell balancing process and ensure all cells are at the same state before regular cycling. It also allows the external SoC counter to set itself to known battery SoC (some SoC counters may take a few cycles to learn the SoC).

#### 5.5. CALIBRATION TO 100% (WEEKLY RECHARGE TO 100%)

Internal cell balancing of the LiFe P Series battery happens during the end of the charging process. It is important for the health of the battery and to ensure the battery capacity does not slip over time that the batteries are charged to 100% at least once every 7 days as a minimum.

#### 5.6. SOC (STATE OF CHARGE) DRIFT

State of Charge drift happens when the product that is calculating SoC builds up an accumulative error. This error is generally due to tolerance of components that measure voltage & current and algorithms used to calculate how full the battery is. Most products will reset its accumulative error when the system gets to 100% SoC or float.

It is important that a well designed battery storage system reaches float stage or 100% as regularly as possible, preferably every 1 to 2 days to reset SoC drift, however can be extended if required.

SoC drift can be addressed in many ways, and some examples are below.

1. Sufficient solar sized to charge batteries to float or 100% on the winter Solstice
2. Backup source installed (grid or generator) to allow charging of batteries during extended bad weather or high load events.
3. Ascertain from PCE manufacture the accuracy of the SoC calculator. If a higher more accurate shunt can be used with the PCE to monitor system SoC, then this should be considered.

## 6. TROUBLESHOOTING

The BMS only enters alarm state when the operation of the battery is outside of the limits of the battery to operate safely.

During normal operation there will be a voltage across the terminals of the batteries. If the BMS activates its protection circuit, once the fault is cleared the battery should restart without external assistance.

The scenario where this may not occur is on low volt disconnect (battery cell voltage low). In this instance the battery will keep its discharge circuit open and will only allow a charge. The battery output will read <4V.

Note: Your installer or PowerPlus Energy should be consulted if your battery will not activate.

### 7.1. OVER DISCHARGED BATTERY RECOVERY

#### 7.1.2. BMS THRESHOLD SOFT SHUTDOWN

Soft shutdown occurs if the voltage in the battery reaches a designated LOW level. In the soft shutdown state, the battery will not provide a DC voltage at its terminal (voltage will be <4V) until the system has been reset.

The time you have to recover the battery when it has performed a soft shutdown will vary depending on model (LiFe12033P should be recovered within 6 hours). The battery will not deliver power to a load from its DC terminals until the battery module reaches a designated recovery voltage.

#### 7.1.3. SOFT SHUTDOWN RECOVERY

This procedure is a guide and should be performed by suitably qualified person.

#### LiFe2433P, LiFe4822P & LiFe4833P

1. Shutdown system following your shutdown procedure.
2. Ensure all loads are switched off.
3. Turn off battery/s via DC circuit breaker and wait 30 seconds.
4. Turn on battery/s via DC circuit breaker.
5. Wait for battery Main Status LED to illuminate.
6. Connect and turn on site PCE.

7. If the PCE starts up, please action a full charge cycle to occur.
8. If battery will not turn on or remain on long enough start a PCE charge. Please follow Hard Shutdown Recovery.

#### LiFe12033P

1. Shutdown system following your shutdown procedure.
2. Ensure all loads are switched off .
3. Turn off battery/s via DC circuit breaker and wait 30 seconds.
4. Turn on battery/s via DC circuit breaker.
  - a. If there is no BMS Status LED activity at all refer Hard Shutdown Recovery.
  - b. BMS Status LED will flash different colours.
3. Wait for battery Main Status LED to illuminate.
4. Connect and turn on site PCE.
5. If the PCE starts up, please action a full charge cycle to occur.
6. If battery will not turn on or remain on long enough start a PCE charge. Please follow Hard Shutdown Recovery.

#### 7.1.3. BMS THRESHOLD HARD SHUTDOWN

Hard shutdown occurs if the voltage in the battery is too LOW to activate the internal BMS. This is a hardware triggered response.

#### 7.1.4. HARD SHUTDOWN RECOVERY

Required Equipment:

1. External DC Charger/Current Limited Power Supply (Available from PowerPlus Energy).
  - 25V Charger/Current Limited Power Supply for LiFe2433P
  - 50V Charger/Current Limited Power Supply for LiFe4833P
  - 120V Charger/Current Limited Power Supply for LiFe12033P
2. Cold Start dongle

### LiF2433P, LiFe4822P & LiFe4833P:

1. Turn off battery/s via on board DC breaker.
2. Connect DC Charger/Current Limited Power Supply to battery, one battery at a time.
3. Check DC Charger is set to battery Nominal Voltage specified in the this manual (See Specification).
4. Turn on battery via DC breaker.
5. Turn on external charger.
6. Wait for at least 30 minutes, the main status LED should turn on.
7. Turn off battery and disconnect startup charger.
8. Reconnect on site PCE to the recovered battery and action a full charging cycle enabling the battery to balance at Continuous Charge Voltage (See Specification) until float reached.

### LiFe12033P

1. Turn off battery/s via on board DC breaker.
2. Connect DC Charger/Current Limited Power Supply to battery, one battery at a time.
3. Check DC Charger is set to battery Nominal Voltage specified in the this manual (see specification).
4. Plug in PowerPlus Energy cold start dongle, use lower RJ45 port located in the lower left of the battery front cover.

5. Turn on battery/s via on board DC breaker.
  - a. If there is no BMS Status LED activity at all, battery needs to be returned to PowerPlus Energy.
  - b. Wait for BMS to turn on.
  - c. BMS Status LED will flash different colours.
4. Turn on external charger.
5. Wait for at least 30 minutes, the main status LED should turn on.
6. Turn off battery and disconnect startup charger.
7. Reconnect on site PCE to the recovered battery and action a full charging cycle enabling the battery to balance at Continuous Charge Voltage (see specification) until float reached.
8. Remove Cold Start dongle

**Important:** Cold start dongle must be removed once batteries have recovered.

**Important:** It is recommended that the battery status is checked once a month for 3 months after battery recovery has occurred to ensure reliable operation of the battery module.

## 7. MAINTENANCE

The battery does not require maintenance itself, however as part of your overall system maintenance schedule it is recommended that the following checks are carried out.

- Check for any obstruction placed around the battery or battery enclosure.
- Check for animals, insects or creatures nesting in or around the battery solution.
- Check for build up of any foreign objects in or around the cabinet.
- Check battery connections and cables for secure fitting or damage.
- Check battery breaker by turning it off and on again.
- Check LED indicators.

## 8. UPGRADING BATTERY CAPACITY

---

It is possible to add additional batteries to an existing LiFe Premium P Series installation at a later date. If you are adding extra capacity, the battery must be of the same type, part number, and specification, unless advised by PowerPlus Energy.

Before adding the new battery the original battery bank and the new battery must be bought up to within ~0.2VDC of each other.

### **This is achieved by:**

Insert the new battery/s to a partially discharged battery bank ensuring the new battery and the battery bank are within 0.2V of each other. Charge complete battery up and maintain our recommended continuous charge voltage until battery has reached float.

Ensure all connected PCE has had relevant charge current and battery capacities revised to suit new increased storage solution.

It is important to ensure the battery is fully charged before discharging.

## 9. CAPACITY TESTING BATTERY

---

The battery capacity can be measured and verified by following the below test procedure. This should be performed using calibrated test equipment and performed by a suitably qualified person.

To determine the battery capacity, the below process should be conducted by a suitably qualified professional and performed at an ambient temperature of 25°C:

- Discharge the battery at 0.5C until the low voltage cut-off is reached, this will be determined by the BMS going open circuit.
- Charge the battery at the recommended continuous charge voltage and 0.5C rate and hold at that voltage for 6 hours.
- Discharge the battery with a constant load at 0.5C until the low voltage cut-off is reached. This will be determined by the BMS going open circuit.
- Record the number of hours it takes to reach low voltage cut-off point.
- Charge the battery at the recommended continuous charge voltage and 0.5C rate for 6 hours.

### **The State of Health of the rated capacity can now be calculated as below and as a % of original capacity:**

$$(((Ah*0.5)*Discharge\ hrs)/Ah)*100 =$$

Ah = Amp Hour Capacity.

0.5 = 0.5C constant load discharge.

100 = Conversion to %.

### **Example:**

LiFe4833P Ah Capacity = 64Ah

Battery time to discharge under test = 1.85hrs

$$= (((64*0.5)*1.85)/64)*100$$

$$= 92.5\%$$

## 10. END OF LIFE

---

When a PowerPlus Energy battery is removed from service it can be returned to PowerPlus Energy for recycling.

Due to the stability and longevity of LFP cylindrical cells, returned batteries will be refurbished and checked so they can be re-purposed for low power applications and made available for community, education and charity projects.

Any lithium cells not suitable for re-purposing will be sent to a licensed recycling facility, where all ferrous and non ferrous metals are separated and then forwarded to our metals recycling partner.

## 11. WARRANTY

---

PowerPlus Energy will protect this product under warranty when it is installed as written in this manual and used as set out in the warranty documents. Any product not being used or installed as outlined will be in violation of the terms and will render the product void of any warranty.

PowerPlus Energy does not cover warranty or any liability for damages or defects caused or from the following:

- Incorrect storage or transportation.
- Incorrect installation and wiring.
- Installed not according to this manual.
- Incorrect operation.
- Inappropriate environmental conditions when operating the battery.
- Failure to follow safety requirements.
- Tampering of or opening the battery.
- Unauthorised repairs or modifications.
- External influences such as physical damage, over charging or electrical damage.
- Used outside of warranty terms and conditions.

# Power ™

**PowerPlus Energy Pty Ltd**  
2 Koornang Road  
Scoresby, Vic, 3179  
Australia  
+61 3 8797 5557  
[info@powerplus-energy.com.au](mailto:info@powerplus-energy.com.au)  
[powerplus-energy.com.au](http://powerplus-energy.com.au)

